

Installation Guide

GE Healthcare Carescape F5 Wall Mount

The purpose of this guide is to:

1. Describe mounting of M-Series Arm (page 1)
2. Describe attachment of Mounting Adapter to F5 (page 2).
3. Describe mounting of F5 on M-Series Arm (page 2)

The following parts and hardware are included in this installation kit (hardware not shown):

Item #	Description	Qty
1	M-Series Arm, 12" Swivel-only	1
2	Mounting Adapter	1
3	M4 x 12 mm Pan Head Machine Screw (PHMS)	4
4	1/8" Hex Wrench	1

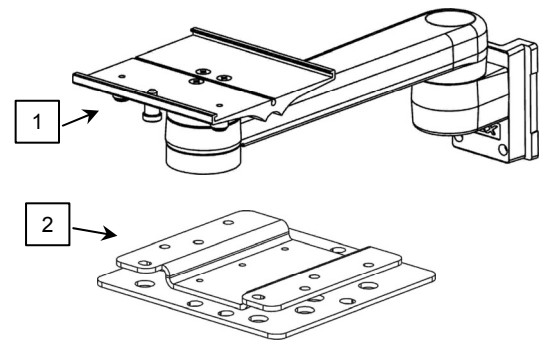

Tools required

- 1/8" hex wrench (provided)
- Phillips screwdriver (not provided).

Mounting the M-Series Arm

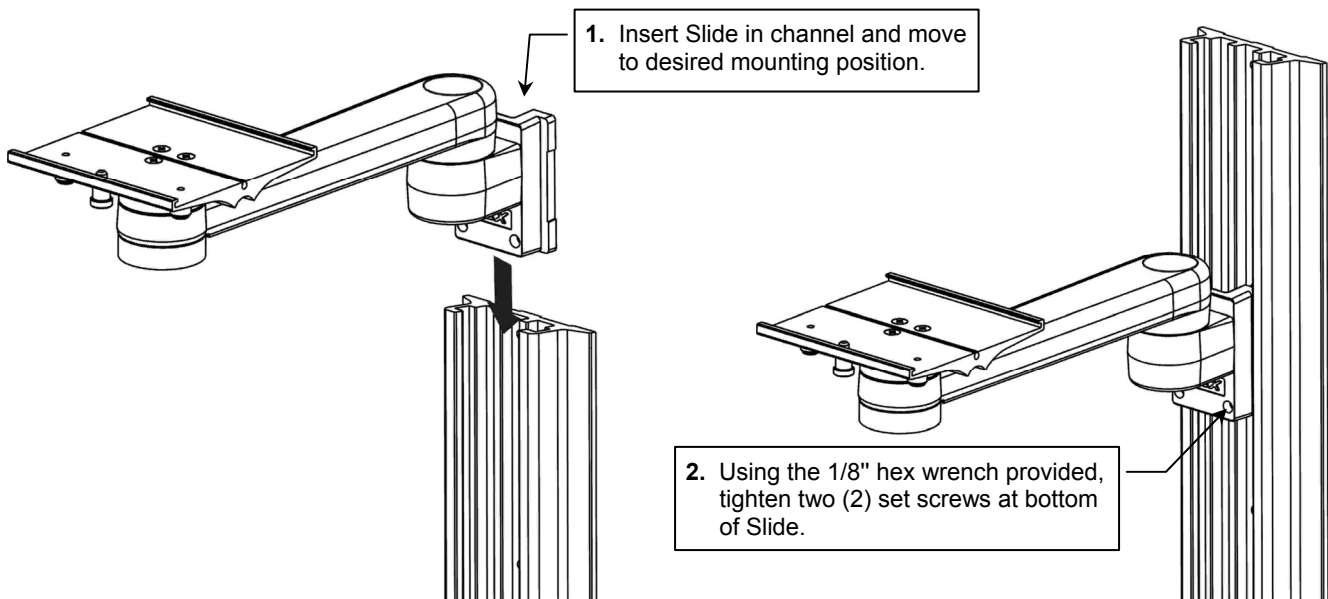

Mounting the F5 on the M-Series Arm

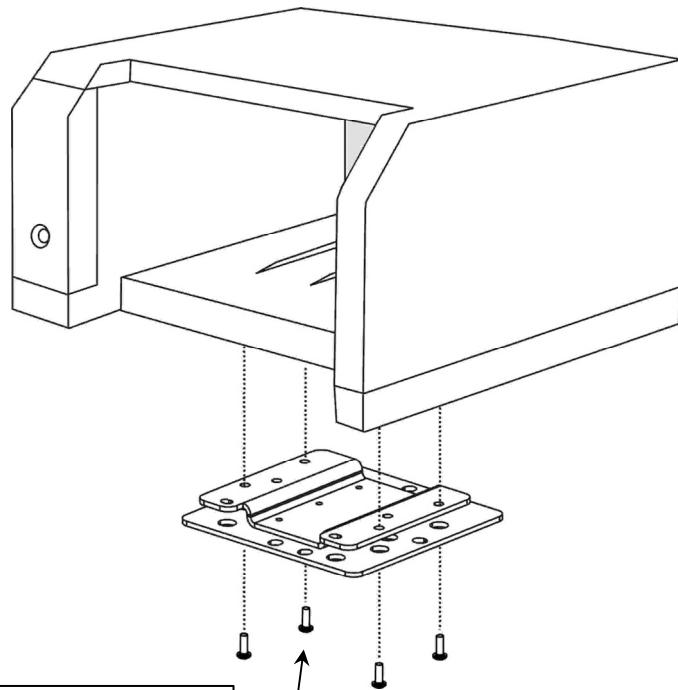

1. Fasten Mounting Adapter to bottom of F5 with four (4) M4 x 12 mm PHMS as shown.

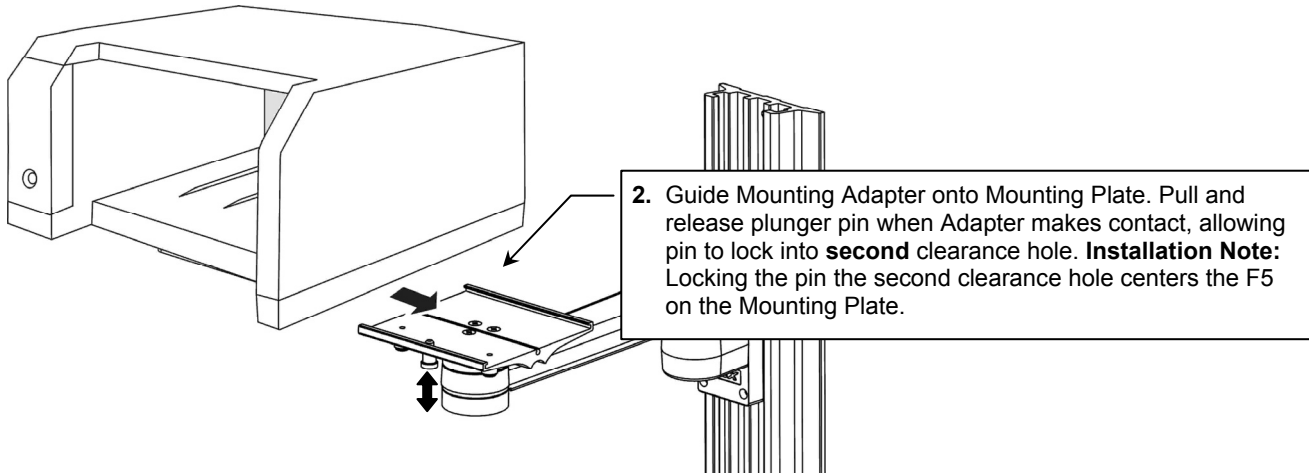

2. Guide Mounting Adapter onto Mounting Plate. Pull and release plunger pin when Adapter makes contact, allowing pin to lock into **second** clearance hole. **Installation Note:** Locking the pin the second clearance hole centers the F5 on the Mounting Plate.

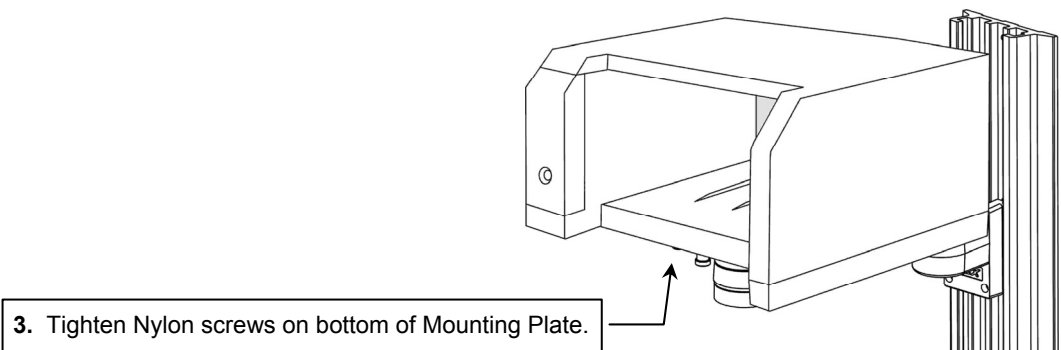

3. Tighten Nylon screws on bottom of Mounting Plate.

M-Series Arm Adjustments

Swivel & Swivel Tension

1. To swivel the device simply push or pull the corners of the device.
2. To adjust the swivel tension, tighten or loosen the Swivel Tension Nut with a 1/2 [13 mm] socket wrench.

Pivot & Pivot Tension

1. To pivot at the Slide, simply push on the side of the Arm or mounted device.
2. To adjust the pivot tension at the Slide, tighten or loosen the Pivot Tension Bolt with a 1/2" [13 mm] socket wrench.

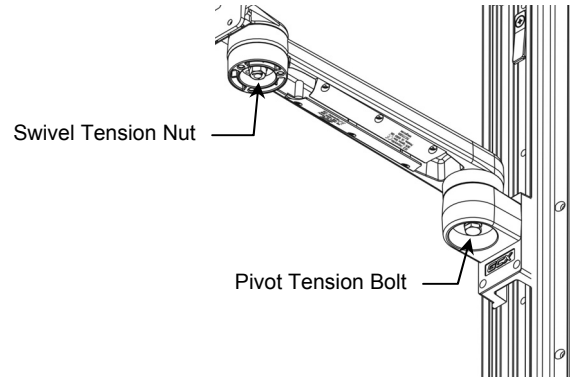

Routine Maintenance of the Mounting Assembly

Periodically inspect all mounting hardware. Tighten or adjust as necessary for optimal operation and safety.

Cleaning the Mounting Assembly

CAUTION: GCX makes no claims regarding the efficacy of the listed chemicals or processes as a means for controlling infection. Consult your hospital's infection control officer or epidemiologist. To clean or sterilize mounted instruments or accessory equipment, refer to the specific instructions delivered with those products.

1. The mounting assembly may be cleaned with most mild, non-abrasive solutions commonly used in the hospital environment (e.g. diluted bleach, ammonia, or alcohol solutions).
2. The surface finish will be permanently damaged by strong chemicals and solvents such as acetone and trichloroethylene.
3. Do not use steel wool or other abrasive material to clean the mounting assembly.
4. Damage caused by the use of unapproved substances or processes will not be covered by warranty. We recommend testing of any cleaning solution on a small area of the mounting assembly that is not visible to verify compatibility.
5. Never submerge or allow liquids to enter the mounting assembly. Wipe any cleaning agents off of the mounting assembly immediately using a water-dampened cloth. Dry mounting assembly thoroughly after cleaning.