

Installation Guide

Philips MP2 IntelliVue Ambulance Mount

The purpose of this guide is to:

1. Describe attachment of Mount to Horizontal or Vertical Surface (page 2).
2. Describe attachment of MP2 to Mount (page 4).

Parts Reference

The following parts and hardware are included with this installation kit (hardware not shown):

Item #	Description	Qty
1	MP2 Dock	1
2	Ambulance Mount	1
3	Spacer Plate	1
4	Cover Plate	1
5	M4 x 8mm Flat Head Machine Screw (FHMS)	1
6	M4 x 20 mm Pan Head Machine Screw (PHMS)	2
7	M6 x 40mm Flat Head Machine Screw (FHMS)	4
8	M6 x 60mm Flat Head Socket Cap Screw (FHSCS)	4
9	M6 Flat Washer	4
10	M6 Kep Nut	4
11	5/32" Hex Wrench	1

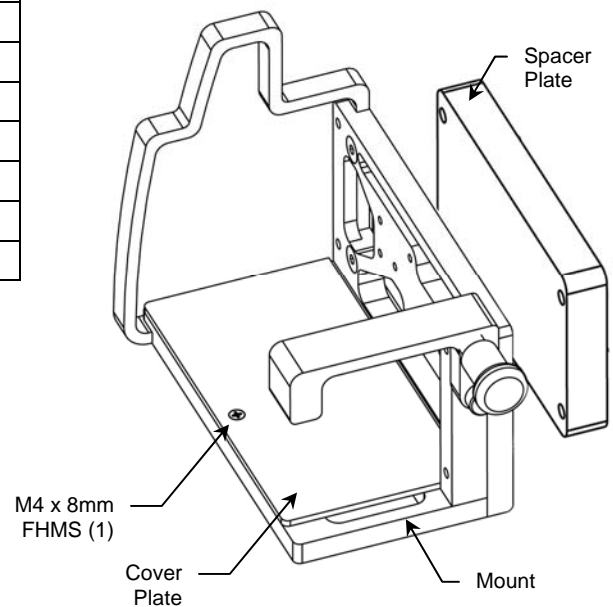
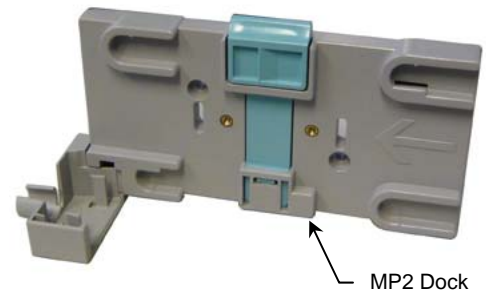

Tools Required

- Phillips screwdriver (not provided)
- 5/32" hex wrench (provided)



CAUTION - Before mounting:

- Ensure that the Vertical or Horizontal Surface you are attaching to has adequate strength to support the Mount and Device.
- If assistance is needed regarding an application, please contact a GCX product specialist at (800) 228-2555.

Mounting to a Horizontal Surface

1. Place the Mount in the desired position. Mark drilling locations through the (4) holes in the bottom of the mount. Drill through the Horizontal Surface using a 8mm (5/16") diameter drill bit.

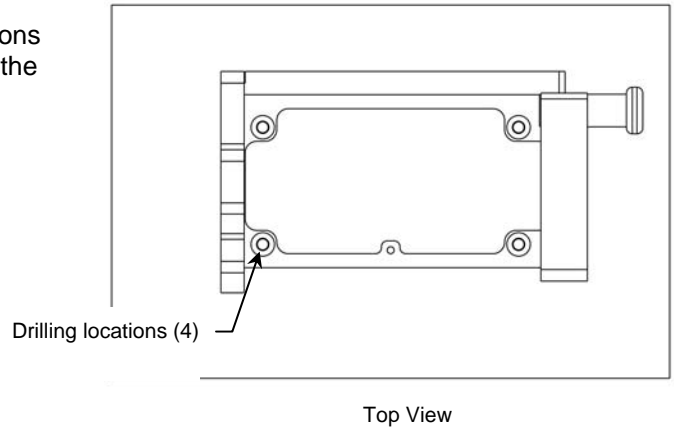

2. Fasten the Mount by running the (4) M6 x 40mm FHMS through the Mount, and drilled holes in the Horizontal Surface. Secure with the (4) Flat Washers and Kep (lock) nuts.

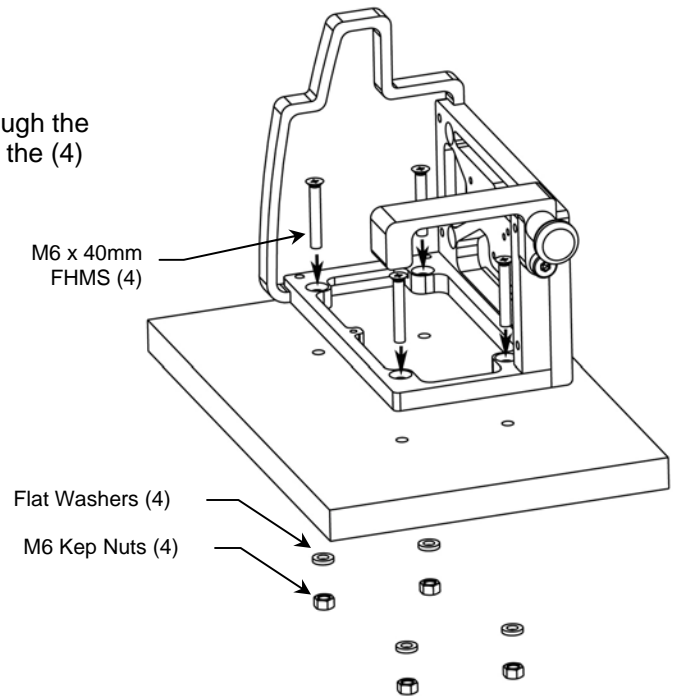

3. Fasten Cover Plate to bottom of Mount using M4 x 8mm FHMS provided.

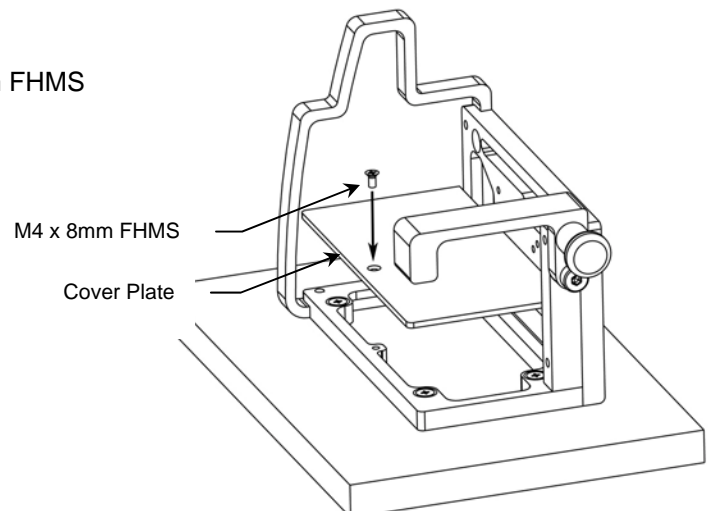

Mounting to a Vertical Surface

1. Place the Mount in the desired position. Mark drilling locations through the (4) holes in the bottom of the mount. Drill through the Horizontal Surface using a 8mm (5/16") diameter drill bit.

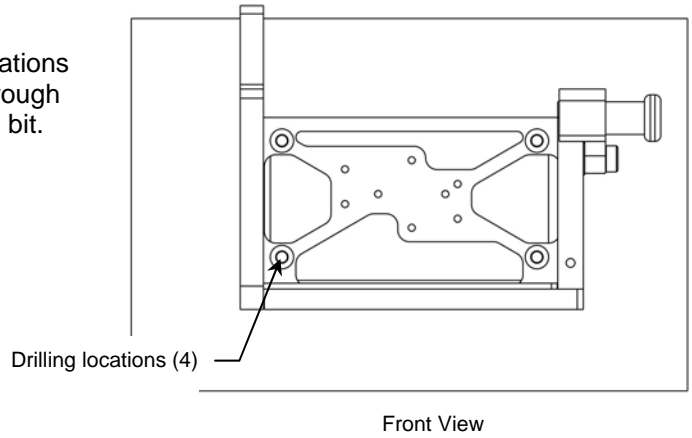

2. Fasten the Mount by running the (4) M6 x 40mm FHMS through the Mount, and drilled holes in the Horizontal Surface. Secure with the (4) Flat Washers and Kep (lock) nuts.

*Depending on the thickness of the Horizontal Surface, M6 x 60mm FHMS (included) may be used to secure mount. A 5/32 hex wrench is provided for this step.

M6 x 40mm FHMS (4)
*M6 x 60mm FHMS (4)

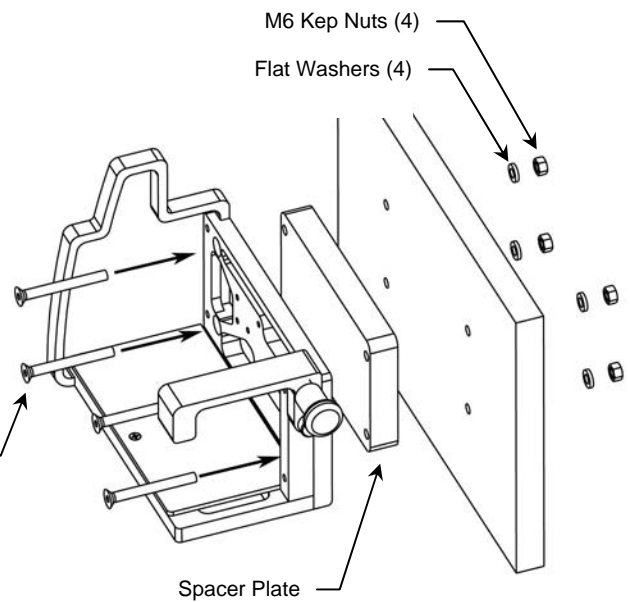

Attaching the MP2 to the Mount

1. Attach the MP2 Dock to the Mount using (2) M4 x 20mm PHMS.

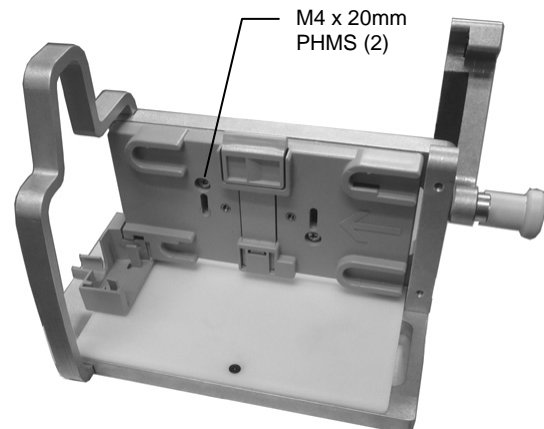

2. Slide the MP2 laterally into the Mount until it clicks into the Dock. Rotate the Latch downward. Press down on the Latch, compressing the foam until the Spring Plunger clicks into position.

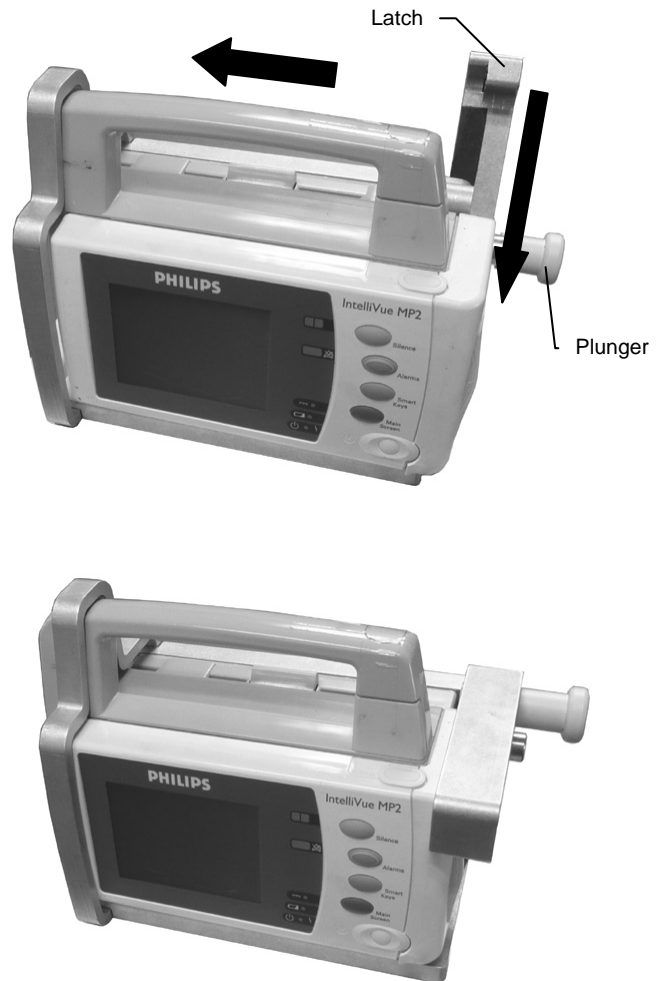

Periodic Maintenance

All fasteners associated with the mounting system should be inspected periodically and tightened or adjusted as necessary for optimal operation and safety.

Cleaning the Mounting Assembly

1. The mounting assembly may be cleaned with most mild, non-abrasive solutions commonly used in the hospital environment (e.g. diluted bleach, ammonia, or alcohol solutions).
2. The surface finish will be permanently damaged by strong chemicals and solvents such as acetone or trichloroethylene.
3. Steel wool or other abrasive material should never be used.
4. Damage caused by the use of unapproved substances or processes will not be warranted. We recommend testing of any cleaning solution on a small area of the arm that is not visible to verify compatibility.
5. Never submerge or allow liquids to enter the arm. Wipe any cleaning agents off the arm immediately using a water-dampened cloth. Dry mounting assembly thoroughly after cleaning.

CAUTION: GCX makes no claims regarding the efficacy of the listed chemicals or processes as a means for controlling infection. Consult your hospital's infection control officer or epidemiologist. To clean or sterilize mounted devices or accessory equipment, refer to the specific instructions delivered with those products.