

**Installation Guide**  
**Universal Power Supply Holster for Roll Stand**  
**(For 2" Diameter Post)**

The Purpose of this guide is to:

1. Describe mounting of Power Supply Holster to Roll Stand Post (page 1)
2. Describe mounting of Power Supply in Holster (page 2)

**Parts Reference**

The following parts and hardware are included in this installation kit (hardware not shown):

Item #	Description	Qty.
1	Power Supply Holster, Roll Stand	1
2	#10-32 x 9/16" Pan Head Machine Screws (PHMS)	2
3	Cable Clip, Roll Stand Post	2

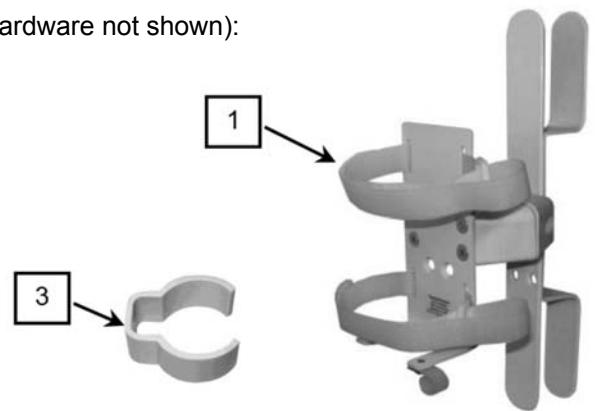

**Tools Required:**

- Philips screwdriver (not provided)

**Mounting the Power Supply Holster on the Roll Stand Post**

1. Fasten Holster to Post with two (2) #10-32 x 9/16" PHMS as shown below.

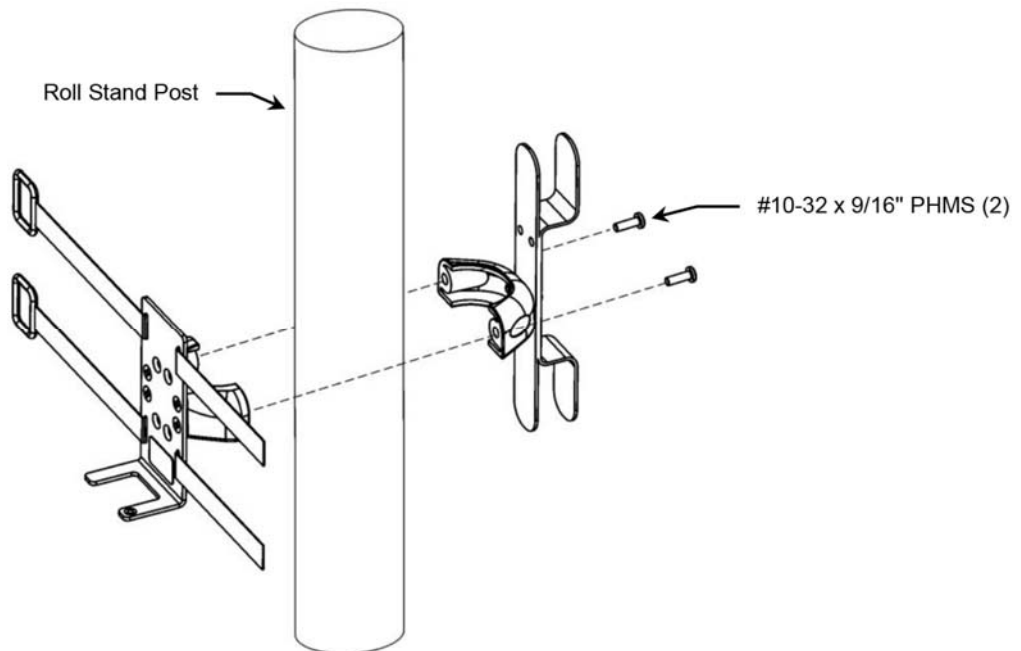

### Mounting the Power Supply in the Holster

1. Place Power Supply in Holster. Insert ends of hook-and-loop straps through rings, pull straps tight, and press firmly.
2. Trim end of hook and loop straps (Fig A).
3. Loop power cord through Nylon retainer as shown (fig B).

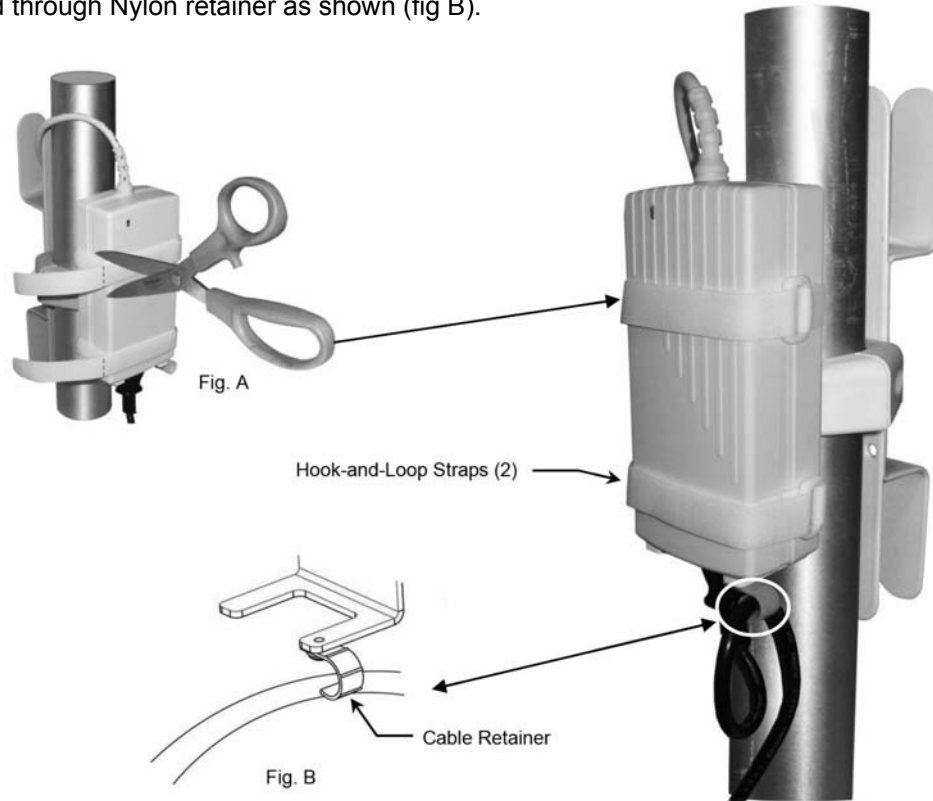

### Cable Management

Two (2) Cable Clips are provided for managing cables along Roll Stand Post. Place loose cables inside Clip and slide Clip onto Post as shown.

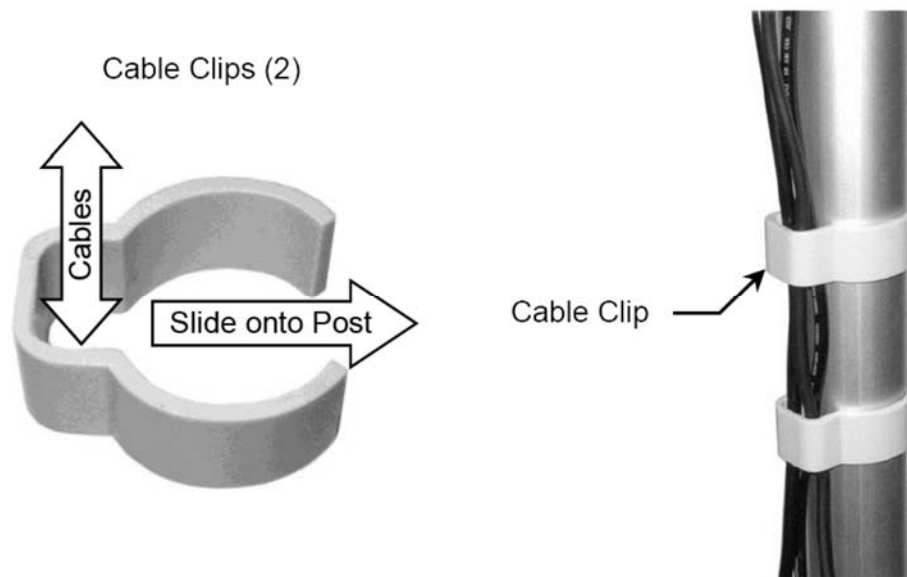

## Routine Maintenance

Periodically inspect all fasteners associated with the mounting assembly. Tighten or Adjust as necessary for optimal operation and safety.

### Cleaning the Mounting Assembly

The mounting assembly may be cleaned with most mild, non-abrasive solutions commonly used in the hospital environment (e.g. diluted bleach, ammonia, or alcohol solutions).

The surface finish will be permanently damaged by strong chemicals and solvents such as acetone or trichloroethylene.

Steel wool or other abrasive material should never be used.

Damaged caused by the use of unapproved substances or processes will not be warranted. We recommend testing of any cleaning solution on a small area of the mounting assembly that is not visible to verify compatibility.

Never submerge or allow liquids to enter the mounting assembly. Wipe any cleaning agents off the mounting assembly immediately using a water-dampened cloth. Dry the assembly thoroughly after cleaning.

 **CAUTION:** GCX makes no claims regarding the efficacy of the listed chemicals or processes as a means for controlling infection. Consult your hospital's infection control officer or epidemiologist. To clean or sterilize mounted devices or accessory equipment, refer to the specific instructions delivered with those products.