

INSTALLATION & OPERATING MANUAL FOR M-SERIES ARMS

-  **WARNING: Do not position support arm or device above a patient.**
- The mounted device may move suddenly due to normal wear or improper adjustment of the tilt and swivel functions (see page 2). Failure to periodically inspect and adjust these functions may result in damage to equipment or injury.

Before mounting the arm:

1. Verify that the Channel has been installed and approved in accordance with the GCX Wall Channel Installation Instructions.
2. Verify the weight of the device to be mounted. This arm is either rated for 30 lbs [13.6 kg] or 60 lbs [27.2 kg], depending on the front-end mounting configuration. Refer to the duty rating label located on top of the arm at the Slide pivot point. It is not recommended that you attempt to use the arm for weights outside of this range.
3. If you are unsure of your application, please contact a GCX product specialist at (800) 228-2555 for assistance.

1. Guide Arm to desired height and tighten two (2) set screws with 1/8" [3mm] hex wrench (provided).

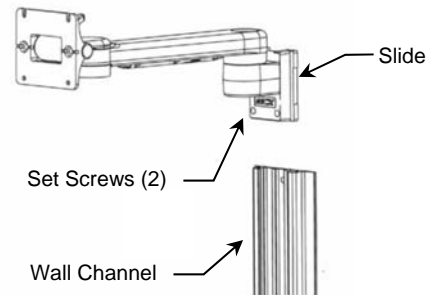

Mounting a Device on the Arm

- Most devices will require the attachment of device-specific mounting hardware provided by GCX. Please attach this hardware in accordance with instructions provided with the Mounting Adapter.
- Most arms will have either a “slide-on” or a “VESA Standard” Mounting Plate at the front of the arm. The arm may have either a Tilt Adjustment Lever installed for rear mounted devices or a Tilt Limit Screw for bottom mounted devices.
- The Tilt Limit Screw may be removed with the 1/4" hex wrench **not** provided.
- The Tilt Adjustment Lever may be removed by rotating the Lever counterclockwise.

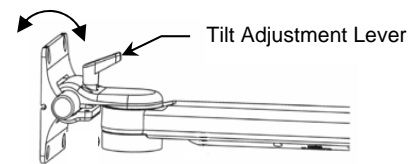

Mounting Device on Slide-on Mounting Plate

1. Pull Spring Plunger at the front of the Mounting Plate and slide device laterally into the Mounting Plate until the Plunger snaps into the clearance hole at the front of the Mounting Adapter.
2. Tighten the Nylon Locking Screws located on bottom or rear of the Mounting Plate.

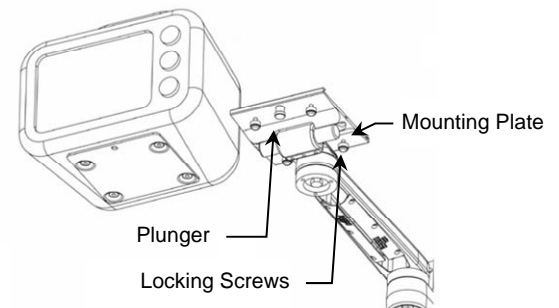

Mounting Device on VESA Standard Mounting Plate

1. Start two (2) customer provided screws by hand into the upper threaded holes in the rear of the device or mounting adapter.
2. Lift the device by guiding the customer provided screws into the slots in the Mounting Plate.
3. Insert two (2) remaining customer provided screws through the lower holes of Mounting Plate.
4. Tighten all fasteners.

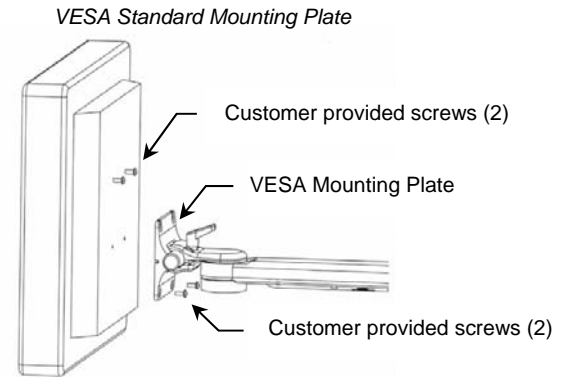

Making Adjustments to the Arm

Tilt & Tilt Tension

1. Loosen the Adjustment Lever (if included).
2. Grasp top and bottom of device and tilt it to desired angle.
3. Tighten the Adjustment Lever (if included).
4. Using a 5/32" hex wrench, equally tighten or loosen the two (2) Tilt Tension Screws.

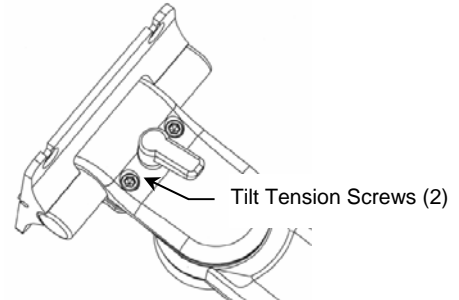

Warning: Tilt tension screws must be torqued to a minimum of 35 in-lbs [4.0 N-m].

Swivel & Swivel Tension

1. In most configurations, the mounted device will swivel at the end of the Arm. To rotate the device simply push or pull the corners of the device.
2. To adjust the swivel tension, tighten or loosen the Swivel Tension Nut with a 1/2 [13 mm] socket wrench.

Warning: Swivel tension nut must be torqued to a minimum of 20 in-lbs [2.3 N-m].

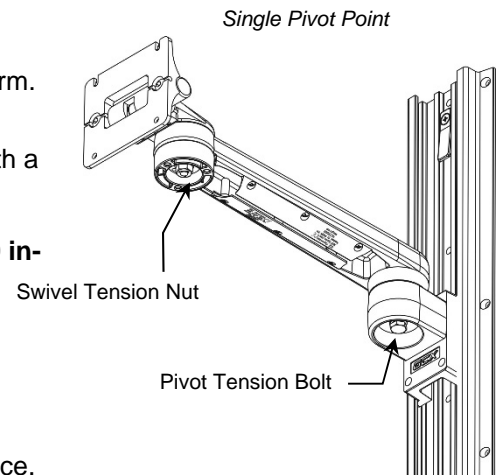

Pivot & Pivot Tension

Pivot Arm/Flush Mount – Single Pivot Point

1. To pivot at the Slide, simply push on the side of the Arm or mounted device.
2. To adjust the pivot tension at the Slide, tighten or loosen the Pivot Tension Bolt with a 1/2 [13 mm] socket wrench.

Articulating Arm – Dual Pivot Points

1. To pivot the Arm at the Slide, simply push on the side of the Arm or mounted device.
2. To pivot the Arm at the midway pivot point, simply push on the side of the front Arm or mounted device while holding the rear arm in place.
3. To adjust the pivot tension at the Slide, tighten or loosen the Pivot Tension Bolt with a 1/2 [13 mm] socket wrench.
4. To adjust the pivot tension, tighten or loosen the Pivot Tension Bolt with a 1/2 [13 mm] socket wrench.

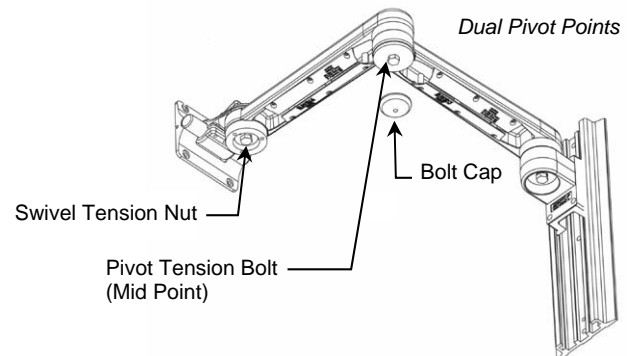

Positioning Arm in Channel

⚠ WARNING: Do not attempt to remove the Arm from the channel while device is mounted.

1. Loosen the set screws in the Slide.
2. To raise or lower the Arm in the channel, relieve the weight of the mounted device by lifting the underside of the Arm, near the device. Simultaneously, push up or pull down the opposite end of the Arm immediately in front of the Slide.
3. Guide Arm to desired height and tighten two (2) set screws with 1/8" [3 mm] hex wrench (provided).

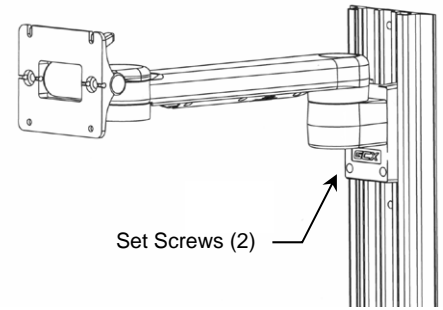

Cable Management

Two cable management features allow placement and flow of cables:

1. An open cavity beneath the arm with flexible cable covers manages cables going between front and rear of the arm.
2. A "pass-through" channel slide allows cables to run behind the arm within the Channel. **Note:** If cable connectors are too large to fit through the pass-through, try placing the cables in the path of the Slide before installing the arm in the Channel. Contact GCX for optional Channel Covers available to further manage the flow of cables in the Channel.

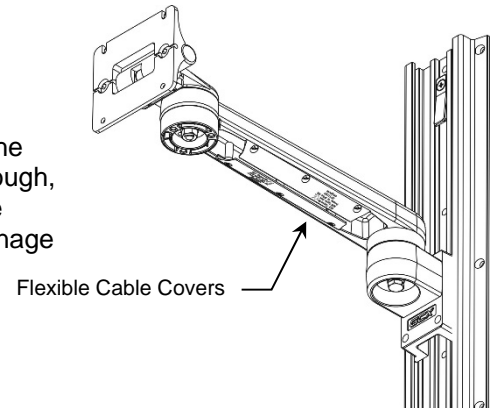

Attachment of Down Post

Some applications may require a Down Post to mount module racks or other devices. Attach Down Post as follows:

1. Align the screw holes in the Post with corresponding threaded holes in the Swivel Fitting.
2. Using the 5/32" [4 mm] hex wrench provided, fasten Down Post to Swivel Fitting with three (3) #10-32 x 3/8" SHCS.

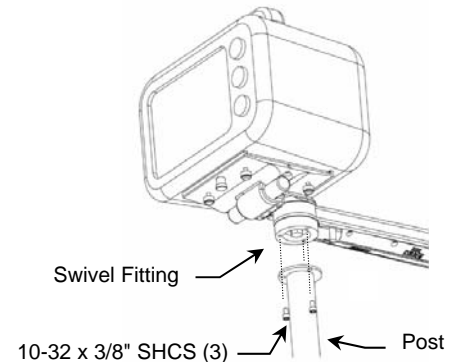

Routine Maintenance

Periodically inspect all hardware associated with the mounting system. Tighten as required for optimal operation and safety.

Cleaning the Mounting Assembly

1. The mounting assembly may be cleaned with most mild, non-abrasive solutions commonly used in the hospital environment (e.g. diluted bleach, ammonia, or alcohol solutions).
2. The surface finish will be permanently damaged by strong chemicals and solvents such as acetone or trichloroethylene.
3. Do not use Steel wool or other abrasive material.
4. Damage caused by the use of unapproved substances or processes will not be warranted. We recommend testing of any cleaning solution on a small area of the arm that is not visible to verify compatibility.
5. Never submerge or allow liquids to enter the arm. Wipe any cleaning agents off of the arm immediately using a water-dampened cloth. Dry the arm thoroughly after cleaning.

CAUTION: GCX makes no claims regarding the efficacy of the listed chemicals or processes as a means for controlling infection. Consult your hospital's infection control officer or epidemiologist. To clean or sterilize mounted devices or accessory equipment, refer to the specific instructions delivered with those products.