

## Installation Guide

### M-Series Arm Kit for Philips Avalon FM50 Monitor



The purpose of this guide is to describe installation of the mounting kit.

#### Parts Reference

The following parts and hardware are included with this installation kit (hardware not shown):

Item #	Description	Qty
1	M-Series Arm Assembly	1
2	Offset Bin Cleat Assembly	1
3	#10-32 x 1/2" Socket Head Cap Screw (SHCS)	3
4	Utility Bin	1
5	Mounting Adapter	1
6	M3 x 12 mm Pan Head Machine Screw (PHMS)	4
7	1/8" Hex Wrench	1
8	5/32" Hex Wrench	1

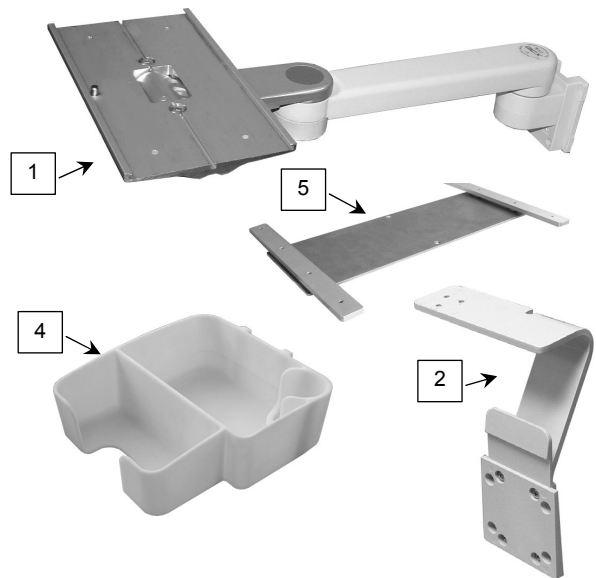

#### Tools Required

- Phillips screwdriver (not provided)
- 1/8" hex wrench (provided)
- 5/32" hex wrench (provided)

#### Attaching Offset Bin Cleat to Arm

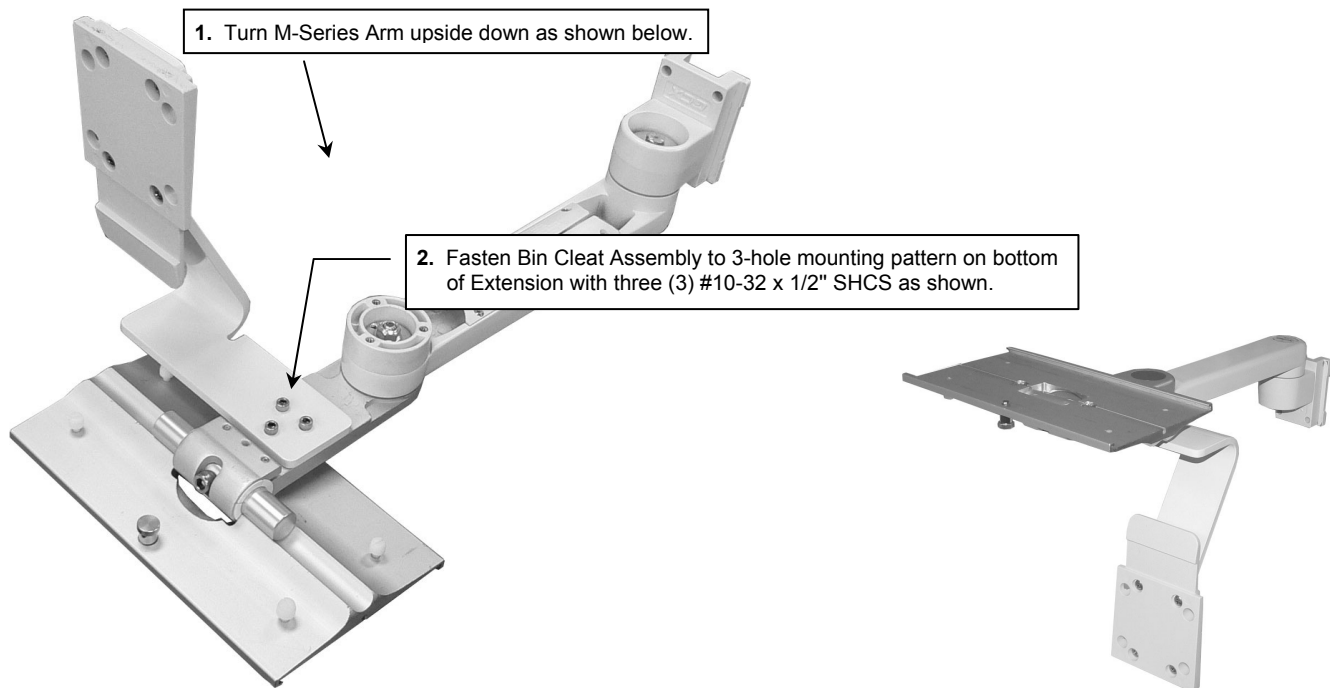

## Mounting the Arm and Utility Bin

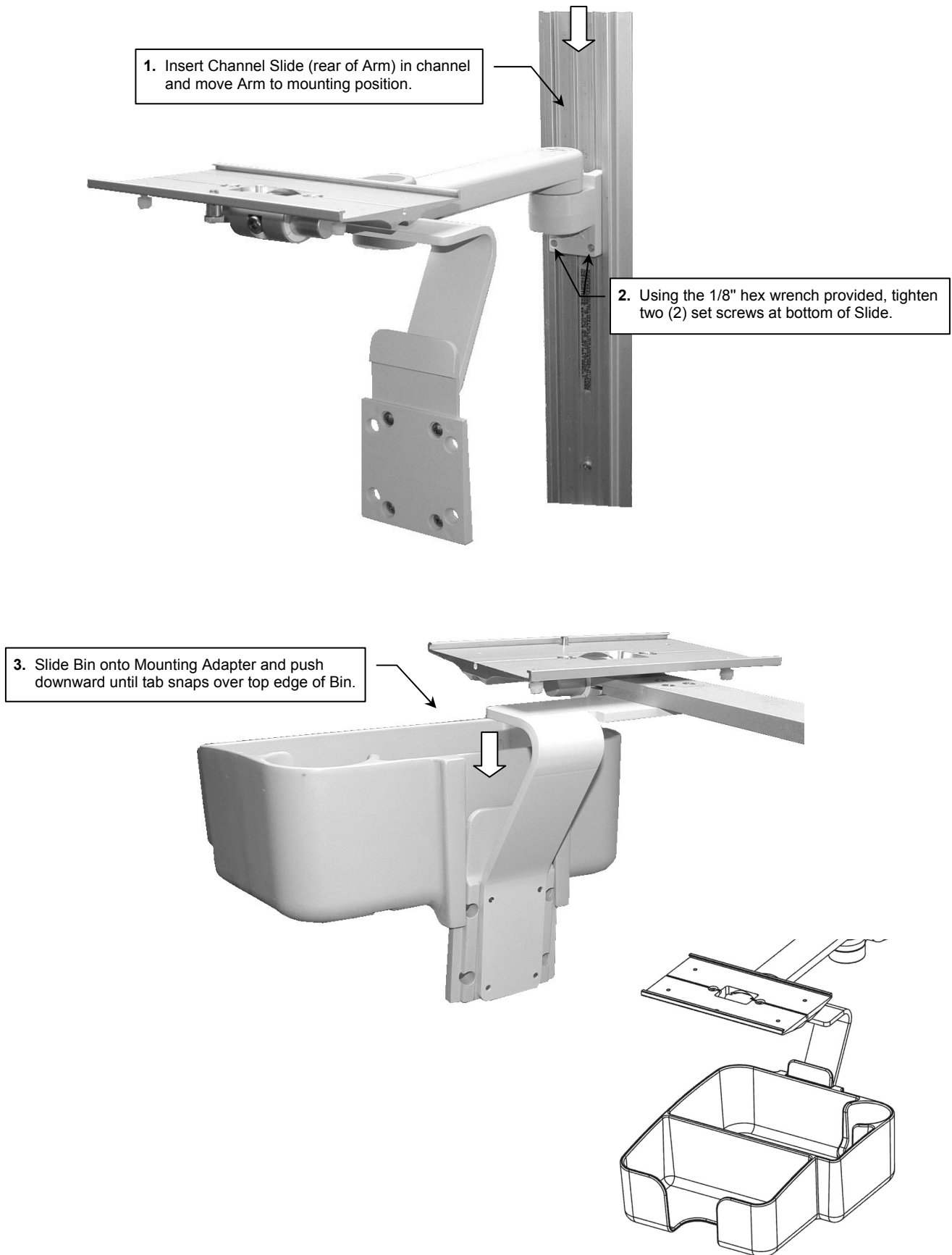

## Attaching Mounting Adapter to Monitor

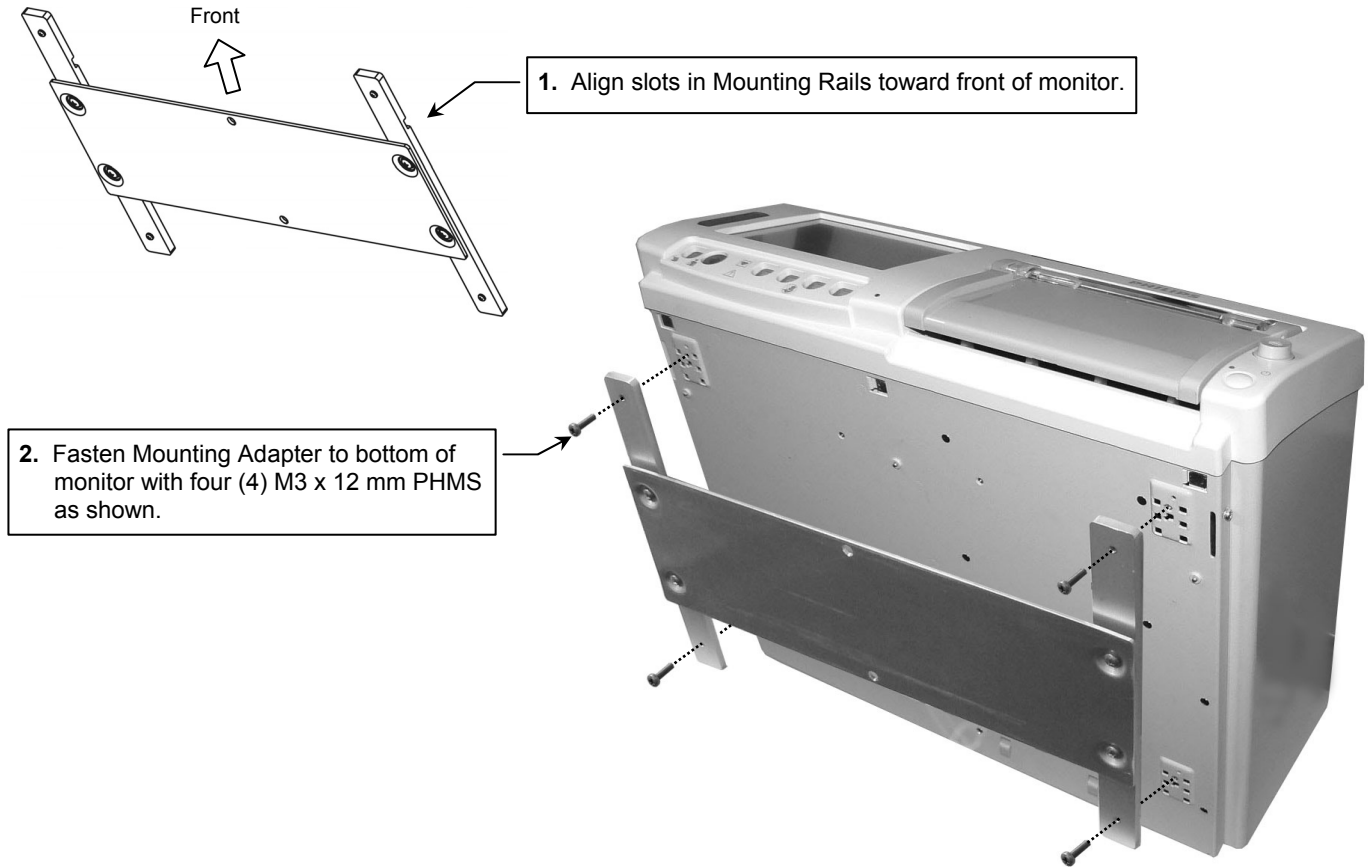

## Mounting the Monitor on the Arm

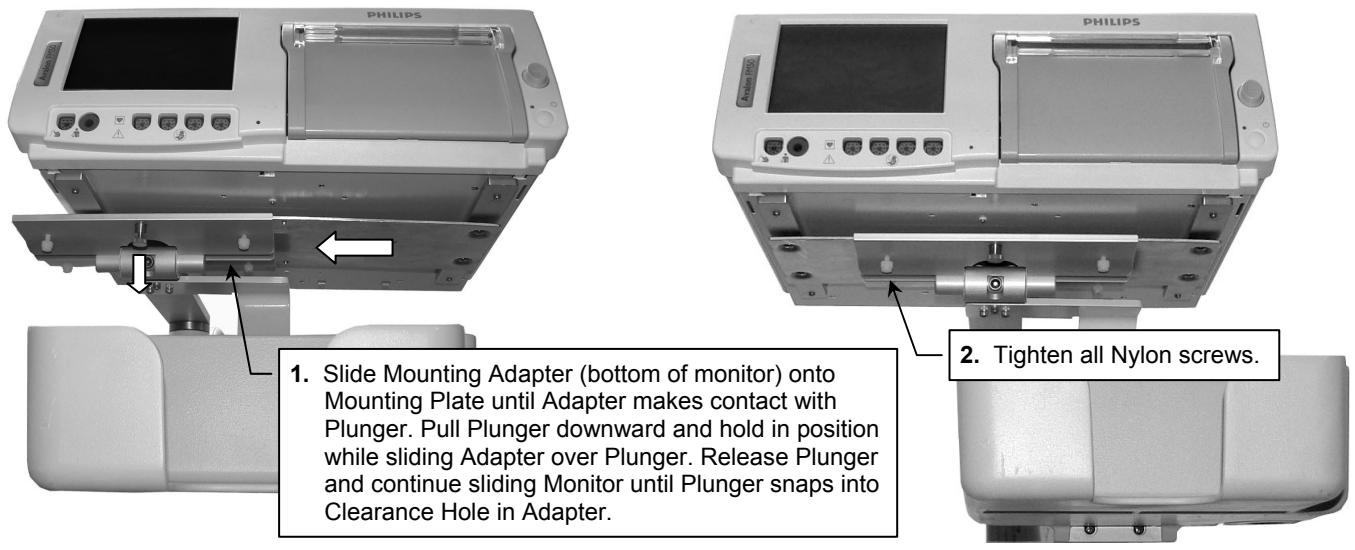

## **M-Series Arm Operation & Adjustments**

Refer to "*Installation & Operation Manual for M-Series Arms*", (DU-WMM-0001) provided with this installation kit for further information about critical adjustment and operation of the M-Series Arm.

### **Periodic Maintenance**

All fasteners associated with the mounting system should be inspected periodically and tightened or adjusted as necessary for optimal operation and safety.

### **Cleaning the Mounting Assembly**

1. The mounting assembly may be cleaned with most mild, non-abrasive solutions commonly used in the hospital environment (e.g. diluted bleach, ammonia, or alcohol solutions).
2. The surface finish will be permanently damaged by strong chemicals and solvents such as acetone or trichloroethylene.
3. Steel wool or other abrasive material should never be used.
4. Damage caused by the use of unapproved substances or processes will not be warranted. We recommend testing of any cleaning solution on a small area of the arm that is not visible to verify compatibility.
5. Never submerge or allow liquids to enter the arm. Wipe any cleaning agents off the arm immediately using a water-dampened cloth. Dry mounting assembly thoroughly after cleaning.

**CAUTION:** GCX makes no claims regarding the efficacy of the listed chemicals or processes as a means for controlling infection. Consult your hospital's infection control officer or epidemiologist. To clean or sterilize mounted devices or accessory equipment, refer to the specific instructions delivered with those products.