

# VSM Premium Roll Stand

PN = 989803206541

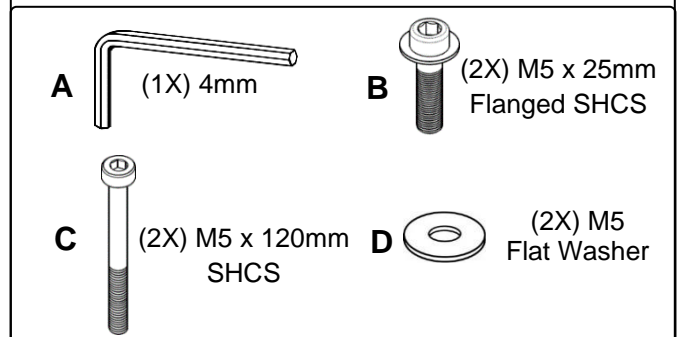

# Assembled View

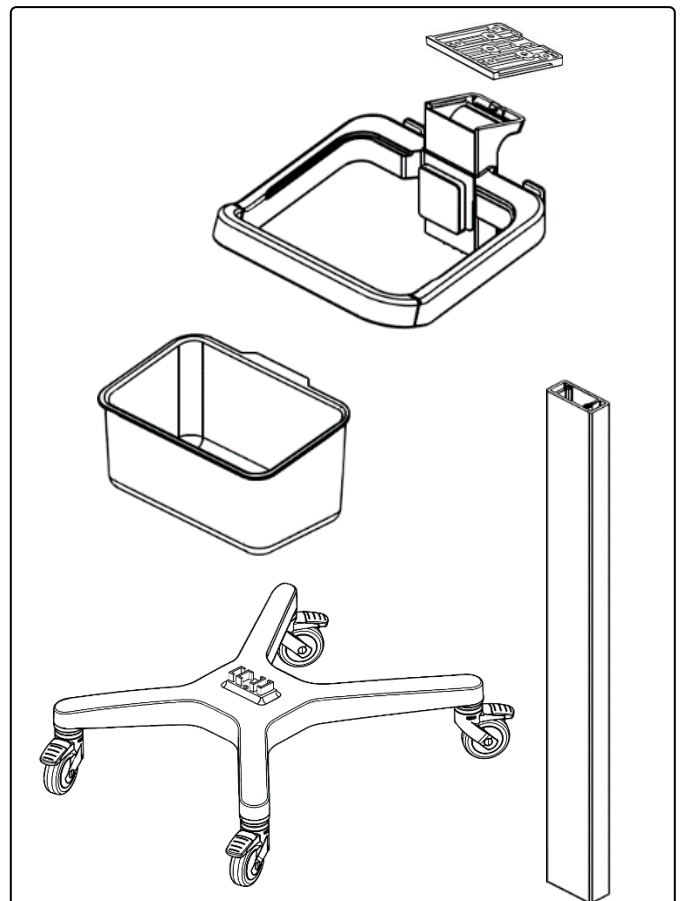
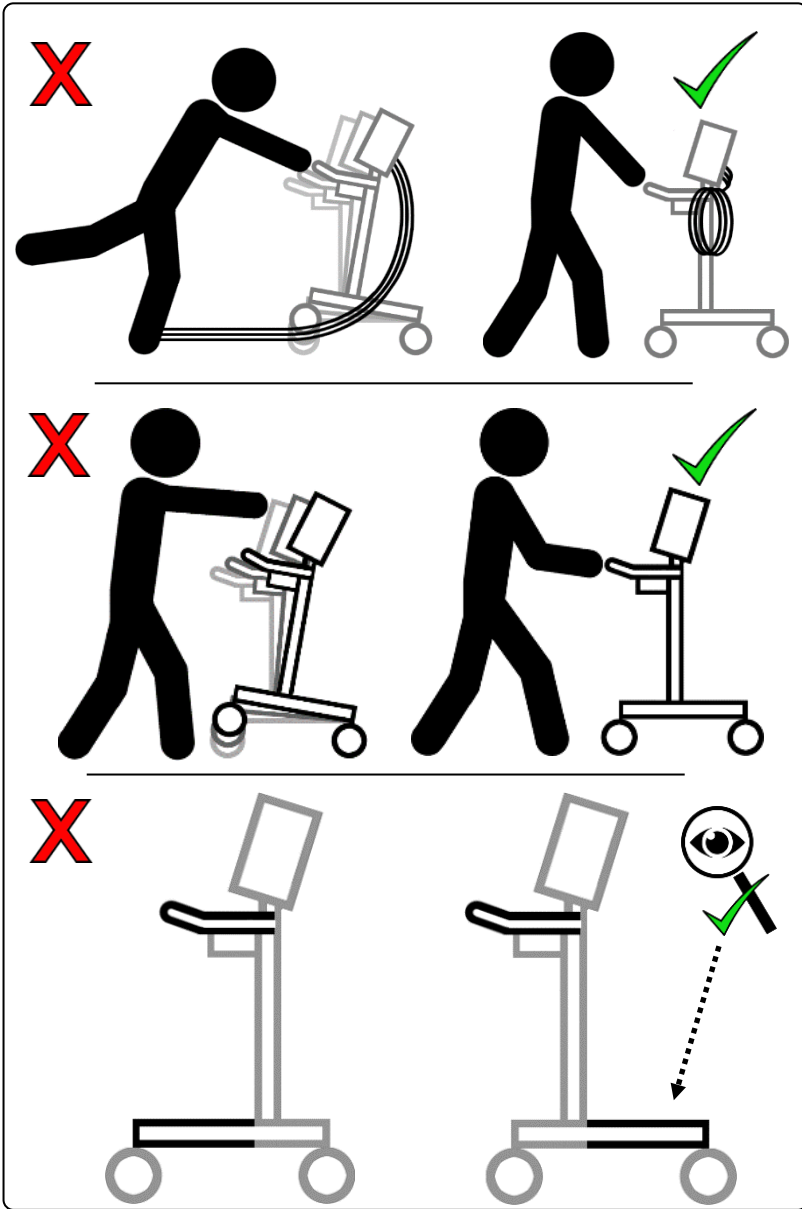
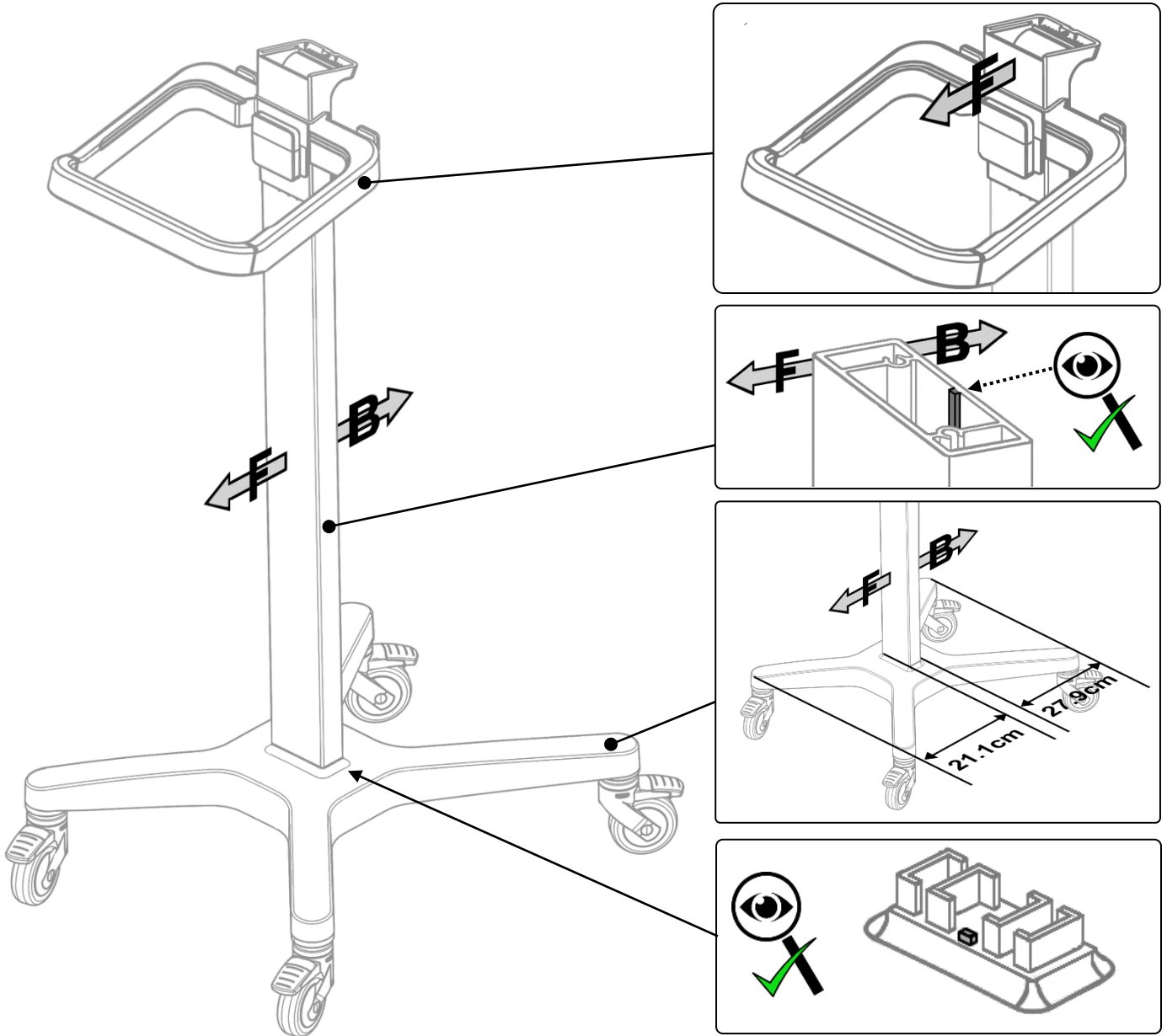
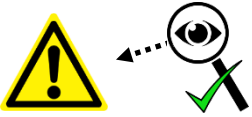

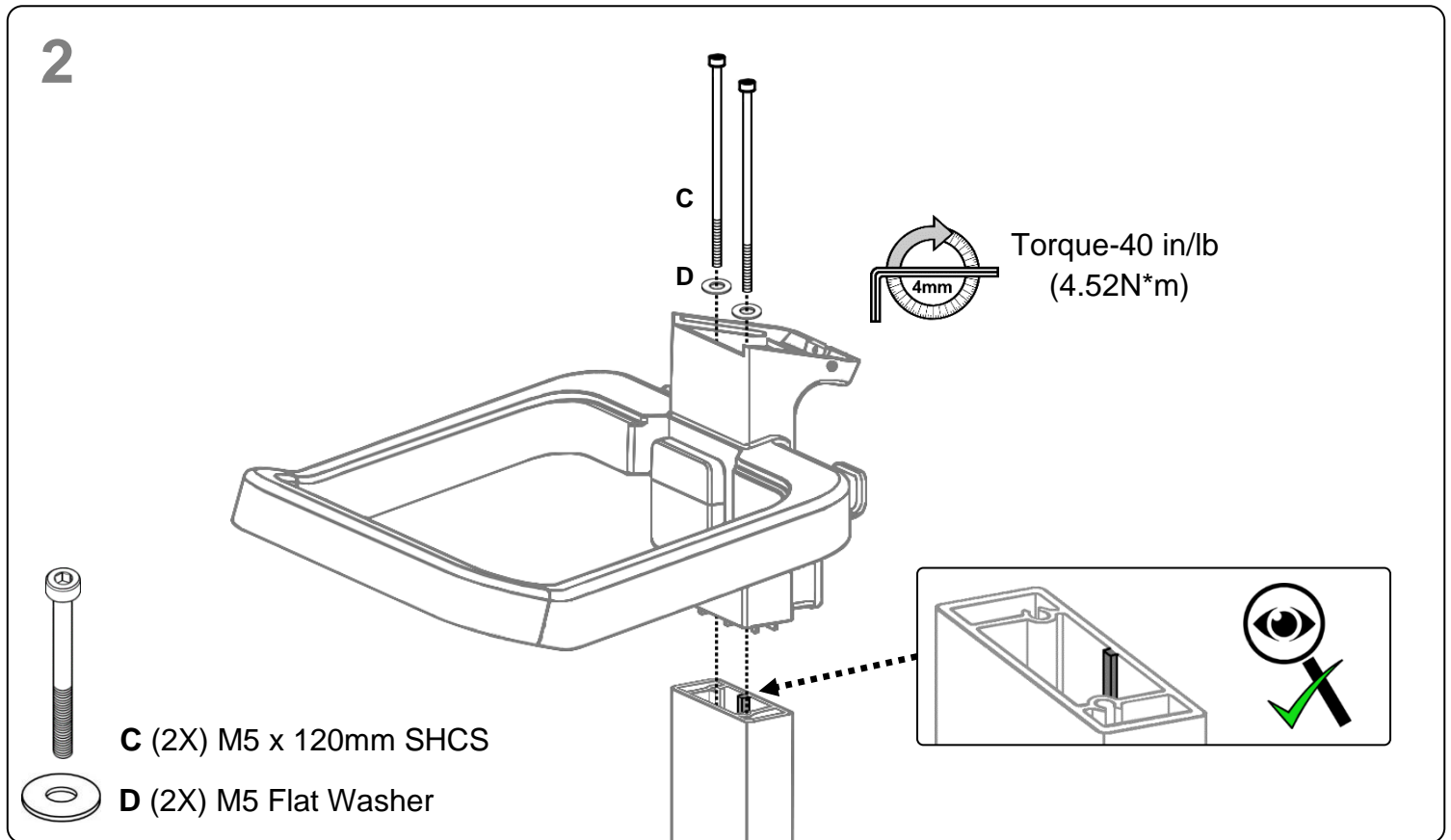
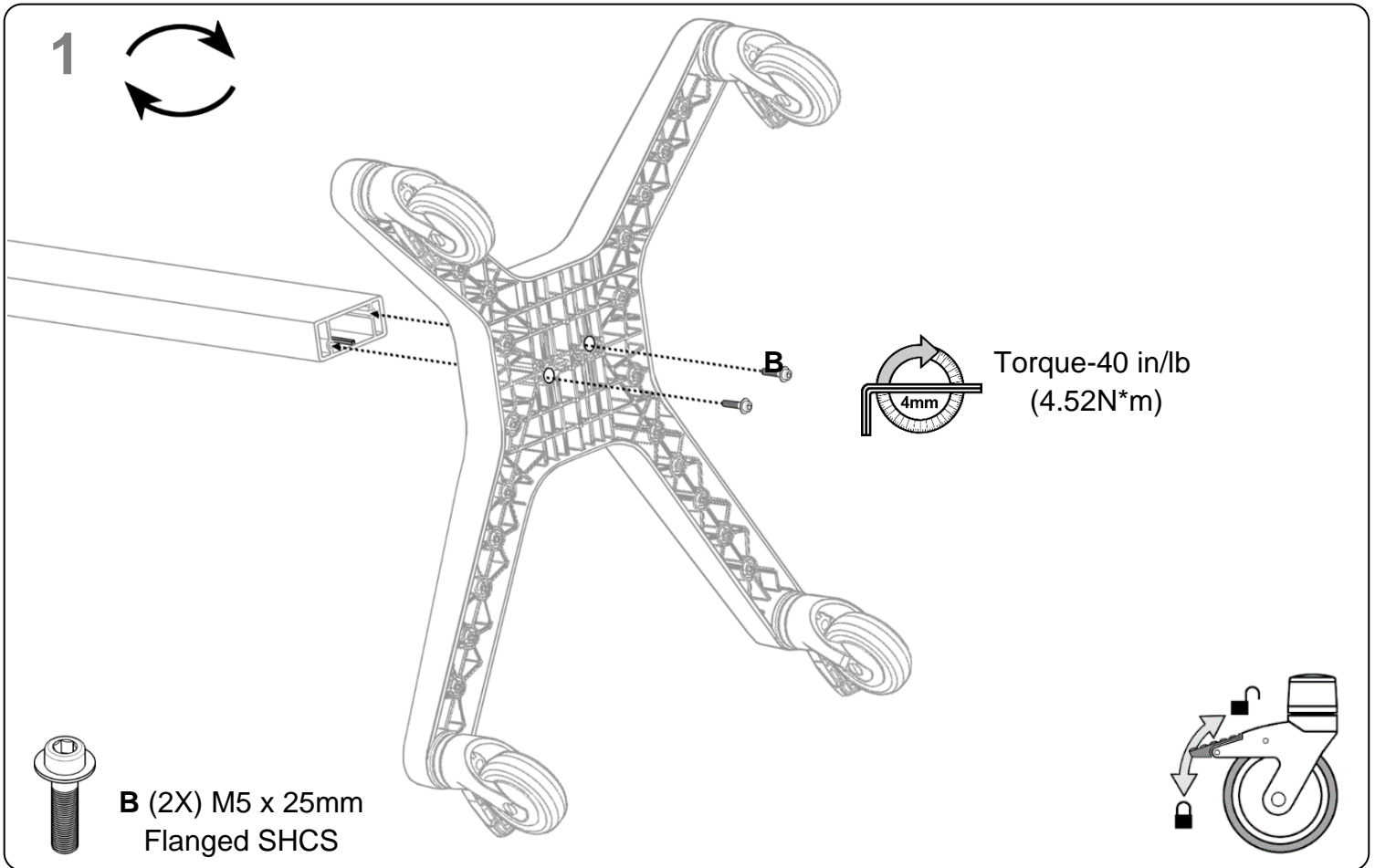

3

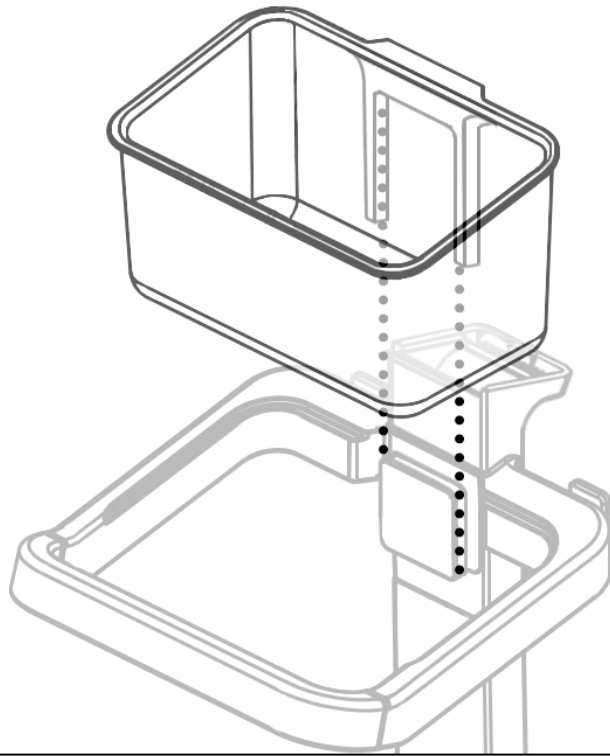

4



(DU-PH-0090-61)

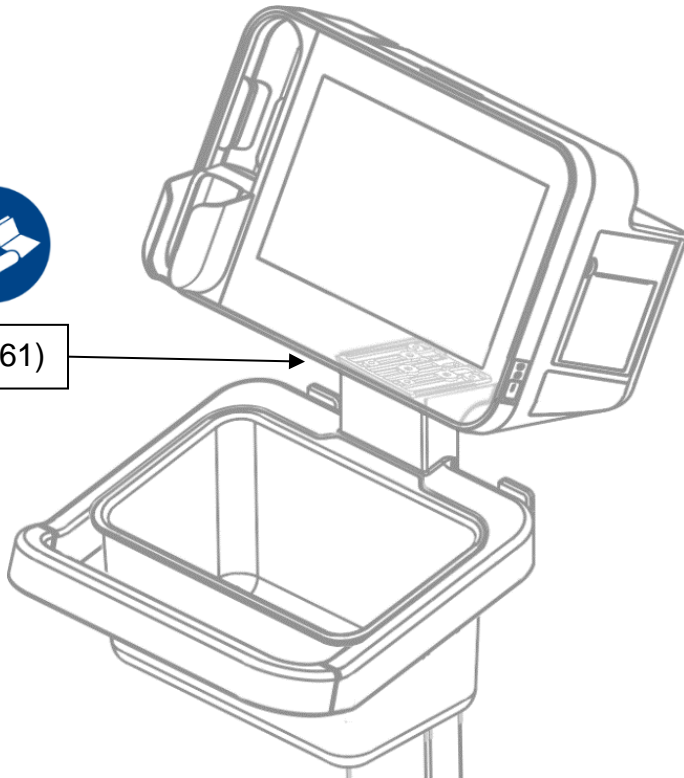

**MAX** 2.3 kg  
(5) lb

# Accessories



See your device IFU for approved accessories.

Multi-Color Handle Wraps  
989803210361  
Green Handle Wraps  
989803210351

Cleaning Wipes Holder  
989803210341

Optional Storage Bin  
989803210331

Caster with Integrated Brake  
GCX P/N= RS-0008-64

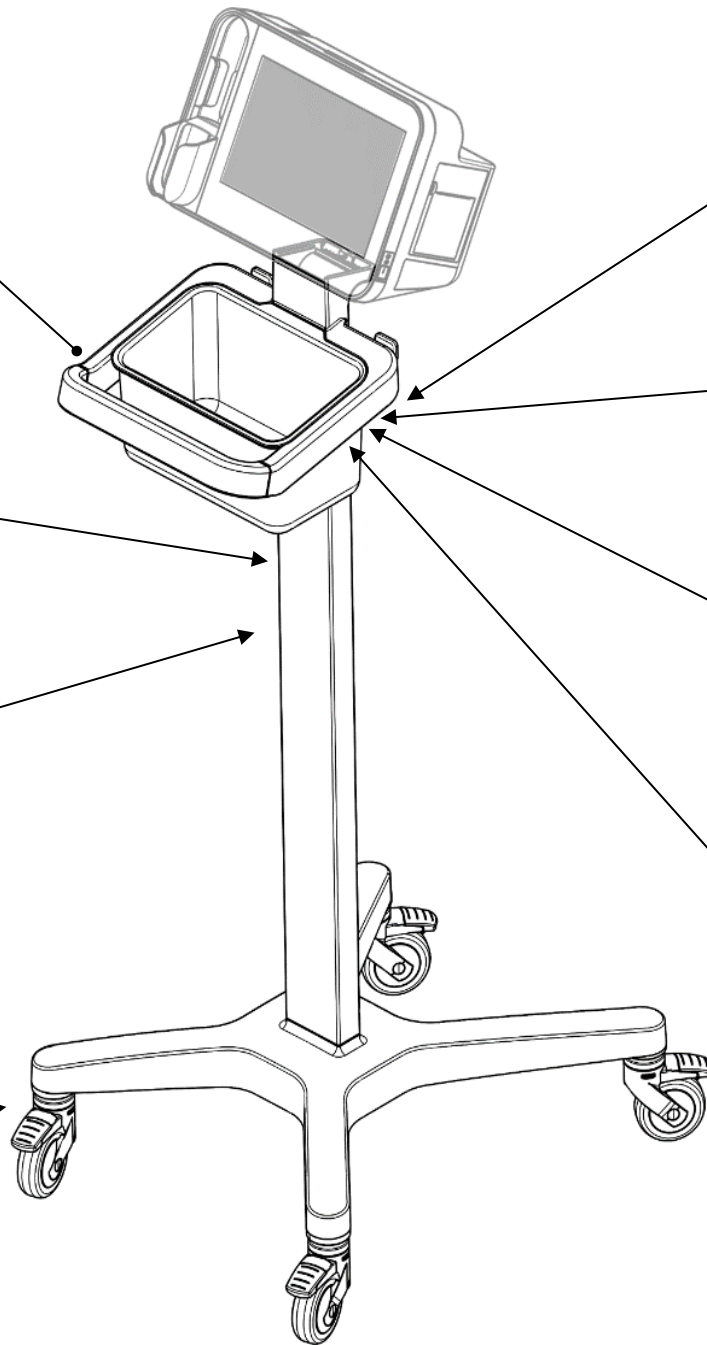

Cable Hook Kit  
989803210371

Temporal (aTemp) Probe  
Holder kit 989803210511

Barcode Scanner Holder  
Kit 989803210381

Holder Kit  
989803210501

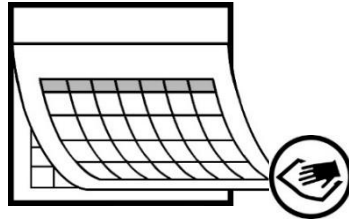

[Cleaning Guidelines](#)

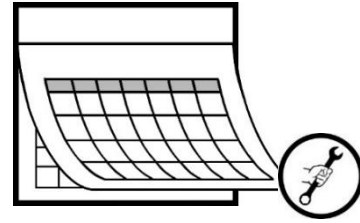

[GCX Technical Support](#)



GCX Corporation  
3875 Cypress Drive  
Petaluma, CA 94954  
USA



EC REP

GCX Corporation  
Building A  
Siriusstraat 45  
5015 BT Tilburg  
Netherlands